

OOPT 2040 : Design

Distributed Vending Machine

TEAM 1

팀장 정연수

팀원 김민환 이승현 조벽정 황유란

Index

2141. Design Real Use Cases	3 ... 14
2142. Define Reports, UI, and Storyboards	15 ... 18
2143. Define Interaction Diagrams	19 ... 27
2144. Define Design Class Diagrams	28... 28
2145. Refine System Architecture	29 ... 29
2147. Design 2040 Traceability Analysis	30 ... 30

2141. Define Essential Use Cases

Use Case	1. Set Up
Actor	None
Purpose	(business use case에 포함)
Overview	(business use case에 포함)
Type	Hidden
Cross Reference	System Functions: R1.1, R1.2, R4.1, R2.4 Use Case: “Message Request”, “Update Stock”, “Select Mode”
Pre-Requisites	N/A
Typical Courses of Events	(A1): User, (A2): Manager, (A3): Other DVM, (S): System 1. (S): (A3)들의 <i>id</i> 를 받아온다. 2. (S): (A3)들의 <i>Item</i> 들에 대한 <i>count</i> 를 받아온다. 3. (S): <i>Item</i> 들의 <i>count</i> 를 업데이트 한다. 4. (S): “ <i>showMode</i> ”를 실행한다.
Alternative Courses of Events	Line 1. (A3)의 응답이 3번 이상 오지 않을 경우, 해당 (A3)은 재고가 없다고 설정한다.
Exceptional Courses of Events	N/A

Use Case	2. Select Mode
Actor	User, Manager
Purpose	(business use case에 포함)
Overview	(business use case에 포함)
Type	Evident
Cross Reference	System Functions: R1.2, R1.1, R1.3, R2.1, R3.1 Use Case: “Set Up”, “Manage Stock”, “Show Item”, “Read Verification Code”
Pre-Requisites	N/A
Typical Courses of Events	(A1): User, (A2): Manager, (A3): Other DVM, (S): System 1.1. (A1): 현장구매모드를 선택한다.

	<p>1.2. (S): “<i>showItem</i>”을 실행한다.</p> <p>2.1 (A1): 선결제코드 입력모드를 선택한다.</p> <p>2.2 (S): “<i>inputVerificationCode</i>”를 실행한다.</p> <p>3.1 (A2): 재고 관리를 선택한다.</p> <p>3.2 (S): “<i>Manage Stock</i>”을 실행한다</p>
Alternative Courses of Events	N/A
Exceptional Courses of Events	N/A

Use Case	3. Manage Stock
Actor	Manager
Purpose	(business use case에 포함)
Overview	(business use case에 포함)
Type	Evident
Cross Reference	System Functions: R1.3, R2.4 Use Case: “Update Stock”
Pre-Requisites	<i>mode</i> 가 3이다.
Typical Courses of Events	(A1): User, (A2): Manager, (A3): Other DVM, (S): System 1. (A2): 추가된 <i>Item</i> 의 재고를 입력한다. 2. (S): 해당 <i>Item</i> 에 대해 “ <i>updateStock</i> ”을 실행한다. 3. (S): “ <i>showMode</i> ”를 실행한다.
Alternative Courses of Events	Line 1. 기존에 해당 자판기에 없던 <i>Item</i> 를 추가할 경우, 새로운 <i>Item</i> 을 추가하여 갱신한다. Line 2. 재고를 감소시킬 경우, <i>count</i> 를 감소시킨다.
Exceptional Courses of Events	Line 1. DVM이 가지고 있는 음료의 종류가 7개를 초과하는 경우 에러를 발생시킨다. Line 2. <i>count</i> < 0이면 [잘못 된 값]이라는 내용의 <i>printe</i> 를 실행한다.

Use Case	4. Show Item
Actor	None
Purpose	(business use case에 포함)

Overview	(business use case에 포함)
Type	Hidden
Cross Reference	System Functions: R2.1, R1.2 Use Case: “Select Mode”
Pre-Requisites	<i>mode</i> 값이 1 이다.
Typical Courses of Events	(A1): User, (A2): Manager, (A3): Other DVM, (S): System 1. (S): 모든 <i>Item</i> 의 선택 버튼을 보여준다.
Alternative Courses of Events	Line 1. 취소 버튼을 누르면 “ <i>showMode</i> ”를 실행한다.
Exceptional Courses of Events	N/A

Use Case	5. Select Item
Actor	User
Purpose	(business use case에 포함)
Overview	(business use case에 포함)
Type	Evident
Cross Reference	System Functions: R2.2, R1.2, R2.1, R2.3 Use Case: “Select Mode”, “Check Stock Count”, “Show Item”
Pre-Requisites	“ <i>showItem</i> ”이 실행됨(mode 값이 1이며 현장구매모드이다.)
Typical Courses of Events	(A1): User, (A2): Manager, (A3): Other DVM, (S): System 1. (A1): 사용자가 구매하고자 하는 <i>Item</i> 을 선택한다. 2. (S): 선택한 <i>Item</i> 에 대해 “ <i>checkStockCount</i> ”를 실행한다. 3. (S): 재고가 현재자판기에 있으면 “Purchase”를 실행한다.
Alternative Courses of Events	Line 1. 취소 버튼을 누르면 “ <i>showMode</i> ”를 실행한다. Line 3 1. 재고가 (A3)에 있으면 “Select Advance Payment”를 실행한다. 2. 선구매 설정에 성공했으면 “Advance Purchase”를 실행한다.
Exceptional Courses of Events	N/A

Use Case	6. Check Stock Count
Actor	None
Purpose	(business use case에 포함)
Overview	(business use case에 포함)
Type	Hidden
Cross Reference	System Functions R2.3, R2.2, R4.1 Use Case: “Select Item”, “Message Request”
Pre-Requisites	<i>Item</i> 이 선택되었다.(mode 값이 1이며 현장구매모드이다.)
Typical Courses of Events	(A1): User, (A2): Manager, (A3): Other DVM, (S): System 1. (S): 선택된 <i>Item</i> 에 대해 현재 자판기에 <i>count</i> > 0인지 확인한다. 2. (S): 현재 자판기에 재고가 없다면 “ <i>sendMessage</i> ”를 통해 (A3)으로부터 재고를 받아온다.
Alternative Courses of Events	N/A
Exceptional Courses of Events	Line 1. 현재 자판기와 다른 모든 자판기에도 <i>count</i> 가 0일 경우 [품절입니다.]이라는 내용의 <i>printe</i> 를 실행한다.

Use Case	7. Update Stock
Actor	None
Purpose	(business use case에 포함)
Overview	(business use case에 포함)
Type	Hidden
Cross Reference	System Functions: R2.4, R1.1, R1.3, R4.2 Use Case: “Set Up”, “Manage Stock”, “Message Response”
Pre-Requisites	갱신 해야하는 <i>Item</i> 정보와 갱신 값이 입력됨
Typical Courses of Events	(A1): User, (A2): Manager, (A3): Other DVM, (S): System 1. (S) : <i>Item</i> 에 대해 <i>count</i> 를 갱신한다.
Alternative Courses of Events	N/A

Exceptional Courses of Events	Line 1. 음료의 종류의 가짓수가 7개를 초과할 경우 [음료 종료 초과] 라는 <i>printe</i> 를 실행한다.
-------------------------------	---

Use Case	8. Purchase
Actor	User
Purpose	(business use case에 포함)
Overview	(business use case에 포함)
Type	Evident
Cross Reference	System Functions: R2.5, R2.7 Use Case: “Check Payment”
Pre-Requisites	1. <i>Item</i> 이 선택되었고 <i>mode</i> 값이 1 이다. 2. <i>count</i> > 0 이다. 3. <i>isAdvance</i> 는 false이다.
Typical Courses of Events	(A1): User, (A2): Manager, (A3): Other DVM, (S): System 1. (A1): 카드를 삽입한다. 2. (S): “ <i>getPaymentResult</i> ”를 실행하여 결과를 받아 반환한다.
Alternative Courses of Events	N/A
Exceptional Courses of Events	Line 2. 1) 결제 실패시 [결제 실패]이라는 내용의 “ <i>printe</i> ”를 실행한다. 2) 사용자가 메시지 창을 확인했으면 재결제를 기다린다.

Use Case	9. Advance Purchase
Actor	User
Purpose	(business use case에 포함)
Overview	(business use case에 포함)
Type	Evident
Cross Reference	System Functions: R2.6, R2.3, R2.7 Use Case: “Select Advance Payment”, “Check Payment”

Pre-Requisites	1. <i>Item</i> 이 선택되었고 <i>isAdvance</i> 가 <i>true</i> 이다. 2. <i>count</i> > 0 이다.
Typical Courses of Events	(A1): User, (A2): Manager, (A3): Other DVM, (S): System 1. (A1): 카드를 삽입한다. 2. (S): “ <i>getPaymentResult</i> ”를 실행하여 결과를 받아 반환한다.
Alternative Courses of Events	N/A
Exceptional Courses of Events	Line 2. 1) 결제 실패시 [결제 실패]이라는 내용의 “ <i>printe</i> ”를 실행한다. 2) 사용자가 메시지 창을 확인했으면 재결제를 기다린다.

Use Case	10. Check Payment
Actor	None
Purpose	(business use case에 포함)
Overview	(business use case에 포함)
Type	Hidden
Cross Reference	System Functions: R2.7, R2.5, R2.6 Use Case: “Purchase”, “Advance Purchase”
Pre-Requisites	카드가 삽입됨
Typical Courses of Events	(A1): User, (A2): Manager, (A3): Other DVM, (S): System 1. (S): “ <i>getResult</i> ”를 실행하여 <i>result</i> 를 받아온다.
Alternative Courses of Events	N/A
Exceptional Courses of Events	Line 1. 1) 정상적인 결제 카드가 아니라면, [결제 실패]라는 내용의 <i>printe</i> 를 실행한다. 2) 사용자가 메시지 창을 확인했으면 재결제를 기다린다.

Use Case	11. Select Advance Payment
Actor	User
Purpose	(business use case에 포함)

Overview	(business use case에 포함)
Type	Evident
Cross Reference	System Functions: R2.8, R2.3, R2.6, R4.1 Use Case: “Check Stock Count”, “Advance Purchase”, “Message Request”
Pre-Requisites	<i>Item</i> 이 선택됨
Typical Courses of Events	(A1): User, (A2): Manager, (A3): Other DVM, (S): System 1. (A1): 선택한 <i>Item</i> 에 대해 선구매를 선택한다. 2. (S): 선택된 <i>Item</i> 에 대해 “ <i>sendMessage</i> ”로 재고를 확인한다. 3. (S): 여전히 재고가 남아있다면 “ <i>sendMessage</i> ”로 다른 자판기에 있는 <i>Item</i> 의 <i>count</i> 를 깎는다. 4. (S): “ <i>showAdvancePurchase</i> ”를 실행한다.
Alternative Courses of Events	
Exceptional Courses of Events	Line 1. 취소를 누를 경우 “ <i>showMode</i> ”로 돌아간다. Line 1. 위치보기를 누를 경우 “ <i>showLocation</i> ”을 실행한다. Line 3. 재고가 없다면 [품절]이라는 내용의 <i>print</i> 를 실행하고, “ <i>showMode</i> ”로 돌아간다.

Use Case	12. Inform Location
Actor	None
Purpose	(business use case에 포함)
Overview	(business use case에 포함)
Type	Hidden
Cross Reference	System Functions: R2.9, R2.8, R4.1 Use Case: “Select Advance Payment”, “Message Request”
Pre-Requisites	<i>Item</i> 이 선택됨 위치보기를 누름 Other DVM의 정보를 알고 있음
Typical Courses of Events	(A1): User, (A2): Manager, (A3): Other DVM, (S): System 1. (S): <i>Item</i> 을 갖고있는 (A3)의 <i>location</i> 를 보여준다.
Alternative	N/A

Courses of Events	
Exceptional Courses of Events	N/A

Use Case	13. Create Verification Code
Actor	None
Purpose	(business use case에 포함)
Overview	(business use case에 포함)
Type	Hidden
Cross Reference	System Functions: R2.10, R2.6 Use Case: “Advance Purchase”
Pre-Requisites	<i>Purchase</i> 의 <i>result</i> 가 <i>true</i> 이다. <i>isAdvance</i> 가 <i>true</i> 이다.
Typical Courses of Events	(A1): User, (A2): Manager, (A3): Other DVM, (S): System 1. (S): 6자리 난수의 선구매 <i>code</i> 를 생성한다.
Alternative Courses of Events	N/A
Exceptional Courses of Events	N/A

Use Case	14. Show Verification Code
Actor	None
Purpose	(business use case에 포함)
Overview	(business use case에 포함)
Type	Hidden
Cross Reference	System Functions: R2.11, R2.10 Use Case: “Create Verification Code”
Pre-Requisites	<i>code</i> 가 생성됨
Typical Courses of Events	(A1): User, (A2): Manager, (A3): Other DVM, (S): System 1. (S): 생성된 <i>code</i> 를 보여준다.

Alternative Courses of Events	N/A
Exceptional Courses of Events	N/A

Use Case	15. Item Out
Actor	None
Purpose	(business use case에 포함)
Overview	(business use case에 포함)
Type	Hidden
Cross Reference	System Functions: R2.12, R2.5, R3.1 Use Case: “Purchase”, “Read Verification Code”
Pre-Requisites	<i>Purchase</i> 의 <i>result</i> 가 <i>true</i> 이거나, “ <i>checkVerificationCode</i> ”의 결과값이 <i>true</i> 이다.
Typical Courses of Events	(A1): User, (A2): Manager, (A3): Other DVM, (S): System 1. (S): 판매된 <i>Item</i> 를 제공한다.
Alternative Courses of Events	N/A
Exceptional Courses of Events	N/A

Use Case	16. Read Verification Code
Actor	User
Purpose	(business use case에 포함)
Overview	(business use case에 포함)
Type	Evident
Cross Reference	System Functions: R1.3, R3.1, R3.2, R3.3, R2.12 Use Case: “Show Mode”, “Check Verification Code”, “Reset Verification Code”, ”Item Out”
Pre-Requisites	Select 모드에서 선구매를 누름.
Typical Courses	(A1): User, (A2): Manager, (A3): Other DVM, (S): System

of Events	1. (A1): <i>code</i> 를 입력한다.
Alternative Courses of Events	N/A
Exceptional Courses of Events	Line 1. 취소를 누를 경우 “ <i>showMode</i> ”로 돌아간다.

Use Case	17. Check Verification Code
Actor	None
Purpose	(business use case에 포함)
Overview	(business use case에 포함)
Type	Hidden
Cross Reference	System Functions: R3.2, R3.1 Use Case: “Read Verification Code”
Pre-Requisites	N/A
Typical Courses of Events	(A1): User, (A2): Manager, (A3): Other DVM, (S): System 1. (S): 입력된 <i>code</i> 가 유효한지 검사한다.
Alternative Courses of Events	N/A
Exceptional Courses of Events	Line 1. 1) 잘못된 <i>code</i> 를 입력한 경우 [코드 오류]이라는 내용의 <i>printe</i> 를 실행한다. 2) 사용자가 메시지 창을 확인했으면 코드 재입력을 기다린다.

Use Case	18. Reset Verification Code
Actor	None
Purpose	(business use case에 포함)
Overview	(business use case에 포함)
Type	Hidden
Cross Reference	System Functions: R3.3, R3.1, R4.1 Use Case: “Read Verification Code”, “Message Request”

Pre-Requisites (Pre condition)	선구매 코드를 갖고있음
Typical Courses of Events	(A1): User, (A2): Manager, (A3): Other DVM, (S): System 1. (S): 사용한 <i>code</i> 정보를 삭제한다. 2. (S): “ <i>sendMessage</i> ”를 통해 모든 자판기에게 해당 <i>code</i> 가 사용되었음을 Broadcast 한다.
Alternative Courses of Events	N/A
Exceptional Courses of Events	N/A

Use Case	19. Message Request
Actor	None
Purpose	(business use case에 포함)
Overview	(business use case에 포함)
Type	Hidden
Cross Reference	System Functions: R4.1, R2.3, R2.6, R2.8, R2.9, R3.3 Use Case: “Check Stock Count”, “Advance Purchase”, “Select Advance Payment”, “Inform Location”, “Reset Verification Code”
Pre-Requisites	<i>Message</i> 의 <i>type</i> 을 알고있음
Typical Courses of Events	(A1): User, (A2): Manager, (A3): Other DVM, (S): System 1.1. (S): Broadcast의 경우, 네트워크에 등록된 모든 (A3)에게 보내고자 하는 <i>Message</i> 를 전달한다. 1.2. (S): 돌려받은 응답을 반환한다. 2.1. (S): 특정 (A3)에게 <i>Message</i> 를 보낼 경우, 해당 (A3)에게 <i>Message</i> 를 전달한다. 2.2 (S): 돌려받은 응답을 반환한다.
Alternative Courses of Events	Line 2.1. 대상 자판기로부터 일정 시간이 지나도 응답이 없을 경우, <i>Message</i> 를 폐기하고 새로운 요청을 보낸다.
Exceptional Courses of Events	Line 2.1. 대상 자판기를 찾을 수 없을 경우, 연결을 끊고 Info 를 출력한다.

Use Case	20. Message Response
----------	----------------------

Actor	None
Purpose	(business use case에 포함)
Overview	(business use case에 포함)
Type	Hidden
Cross Reference	System Functions: R4.2, R4.1 Use Case: “Message Request”
Pre-Requisites	<i>Message</i> 의 <i>type</i> 과 <i>src_id</i> 를 알고있음
Typical Courses of Events	(A1): User, (A2): Manager, (A3): Other DVM, (S): System 1. (S): 전달받은 Message Protocol에 따라 응답을 만든다. 2. (S): <i>Message</i> 를 보내온 (A3)에게 응답을 보낸다.
Alternative Courses of Events	N/A
Exceptional Courses of Events	1. 알 수 없는 종류의 <i>Message</i> 를 전달받을 경우, 알수 없음을 응답한다.

2142. Define Reports, UI, and Storyboards

(1) Select Mode



(2) Show Item

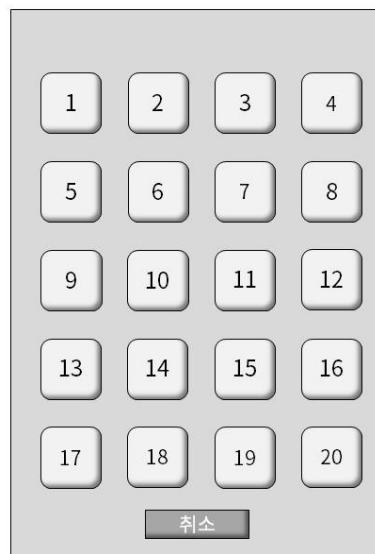

(3) Purchase, Advance Purchase

카드를 삽입해주세요

결제금액 : 0000원

2021-04-29 00:00

취소

(4) Read Verification Code

인증번호를 입력하세요

1	2	3
4	5	6
7	8	9

취소 확인

(5) Manage Stock

음료 :
콜라
사이다
환타
...

수량 :

6) Select Advance Purchase

음료 :

금액 : 0000원

7) Show Verification Code

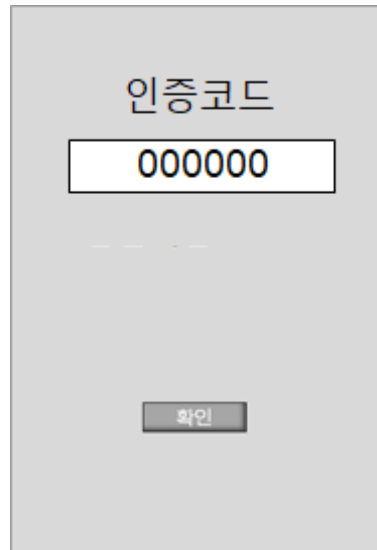

A gray rectangular screen with the text "인증코드" (Verification Code) at the top. Below it is a white rectangular box containing the number "000000". At the bottom center is a small gray button with the text "확인" (Confirm).

8) Inform Location

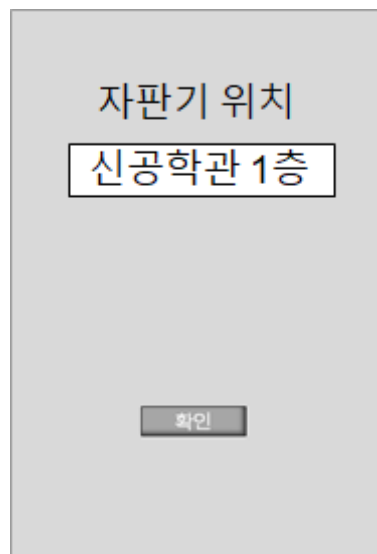

A gray rectangular screen with the text "자판기 위치" (Vending Machine Location) at the top. Below it is a white rectangular box containing the text "신공학관 1층" (New Engineering Building 1st Floor). At the bottom center is a small gray button with the text "확인" (Confirm).

2143. Define Interaction Diagrams

(1) Set Up

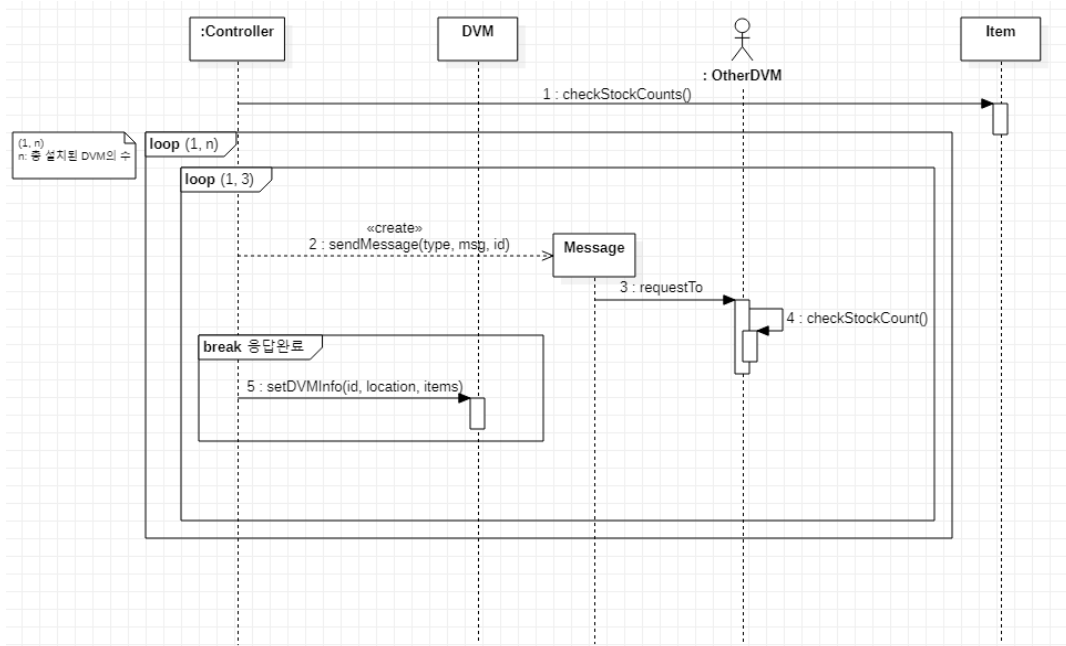

(2) Select Mode

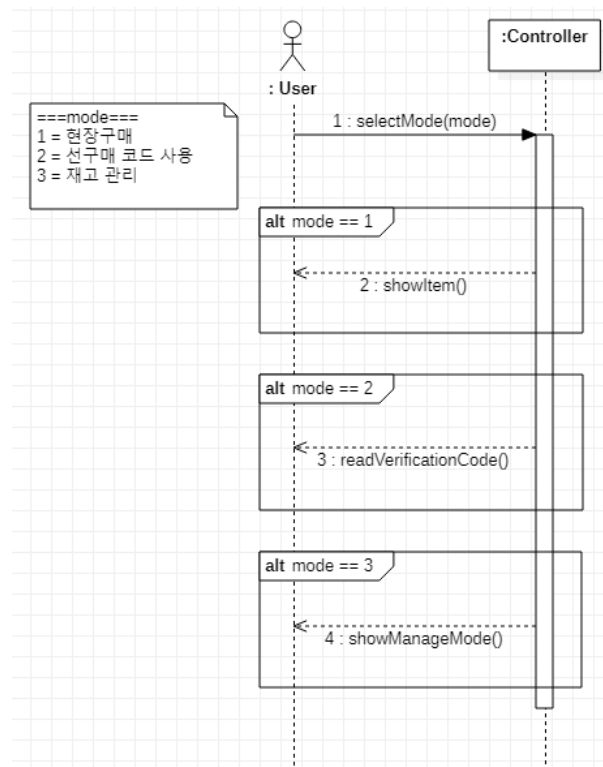

(3) Manage Stock

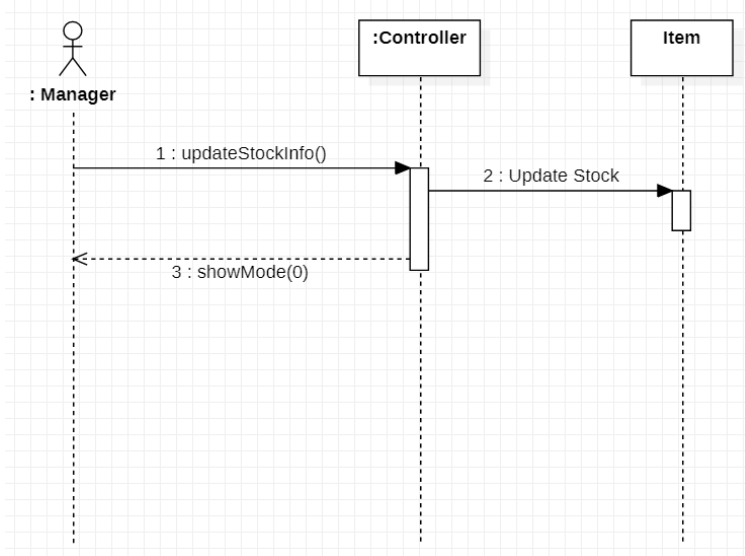

(4) Show Item

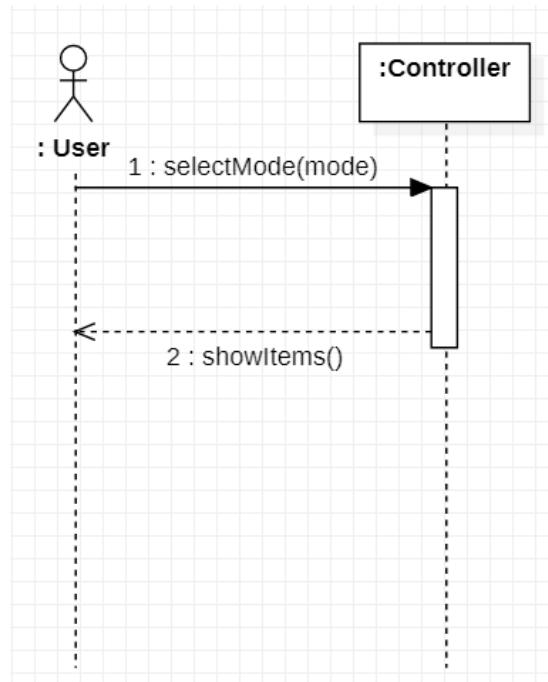

(5) Select Item

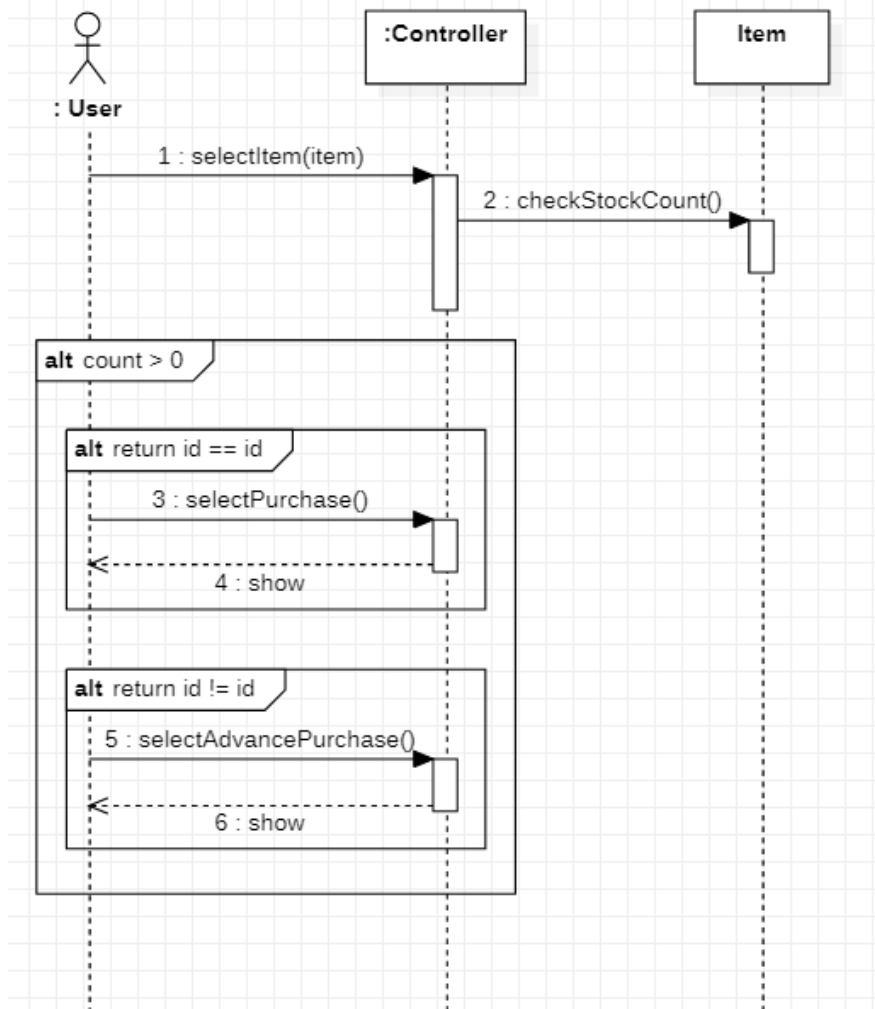

(6) Check Stock Count

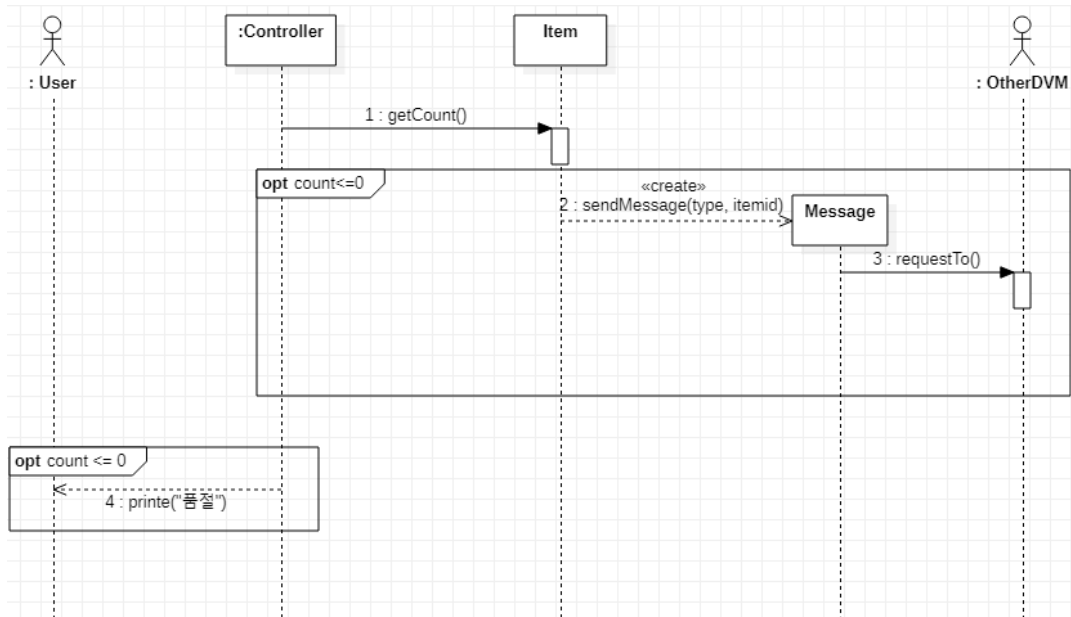

(7) Update Stock

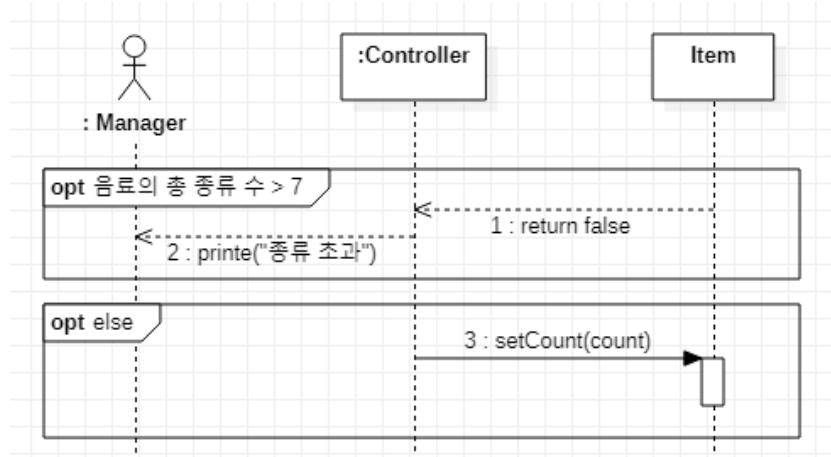

(8) Purchase

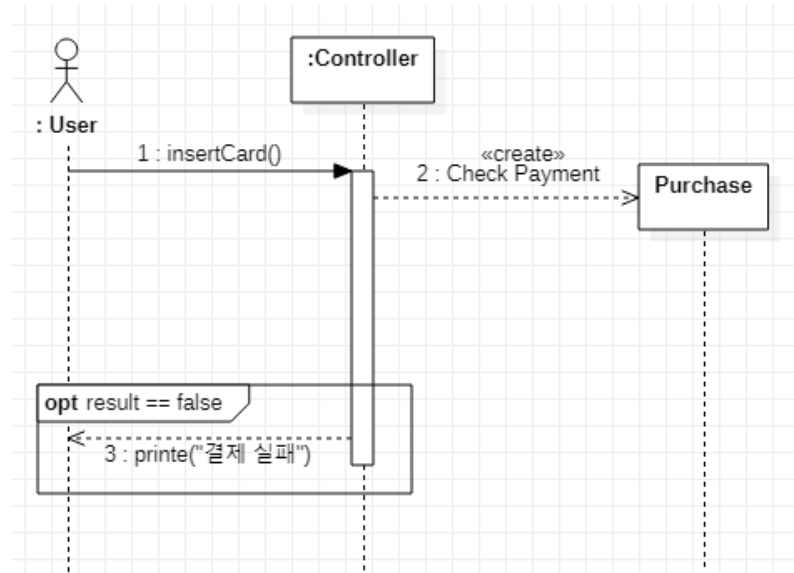

(9) Advance Purchase

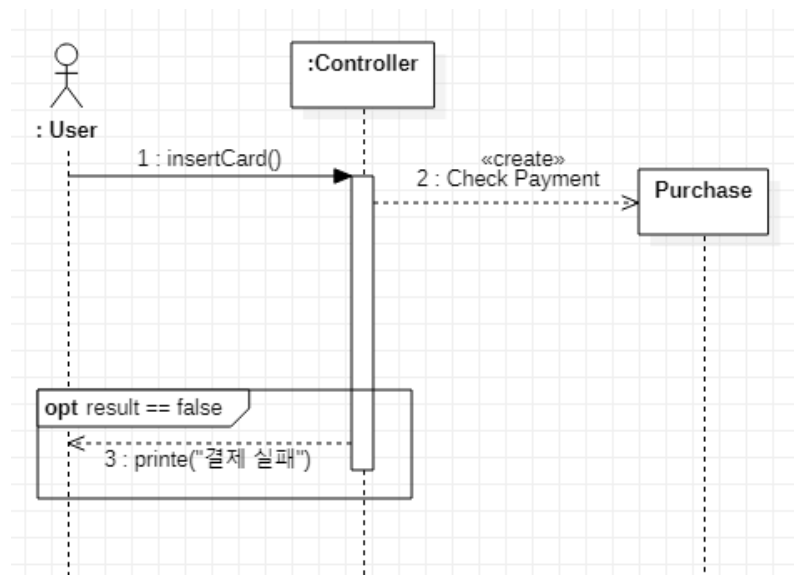

(10) Check Payment

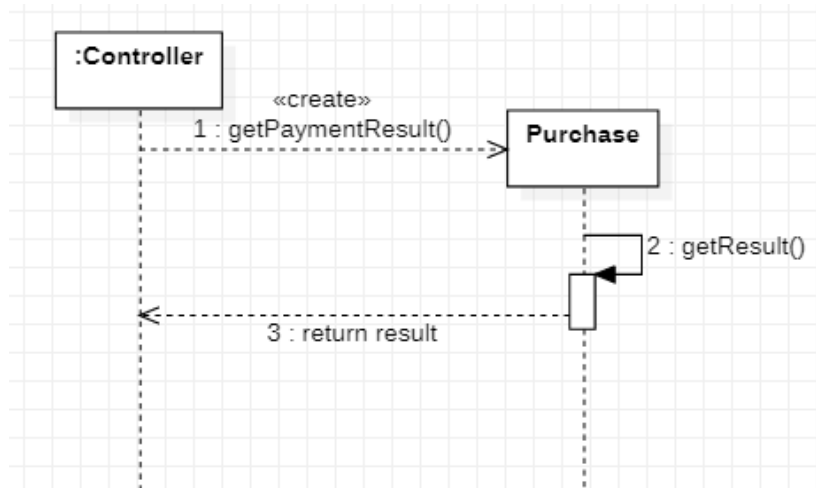

(11) Select Advance Payment

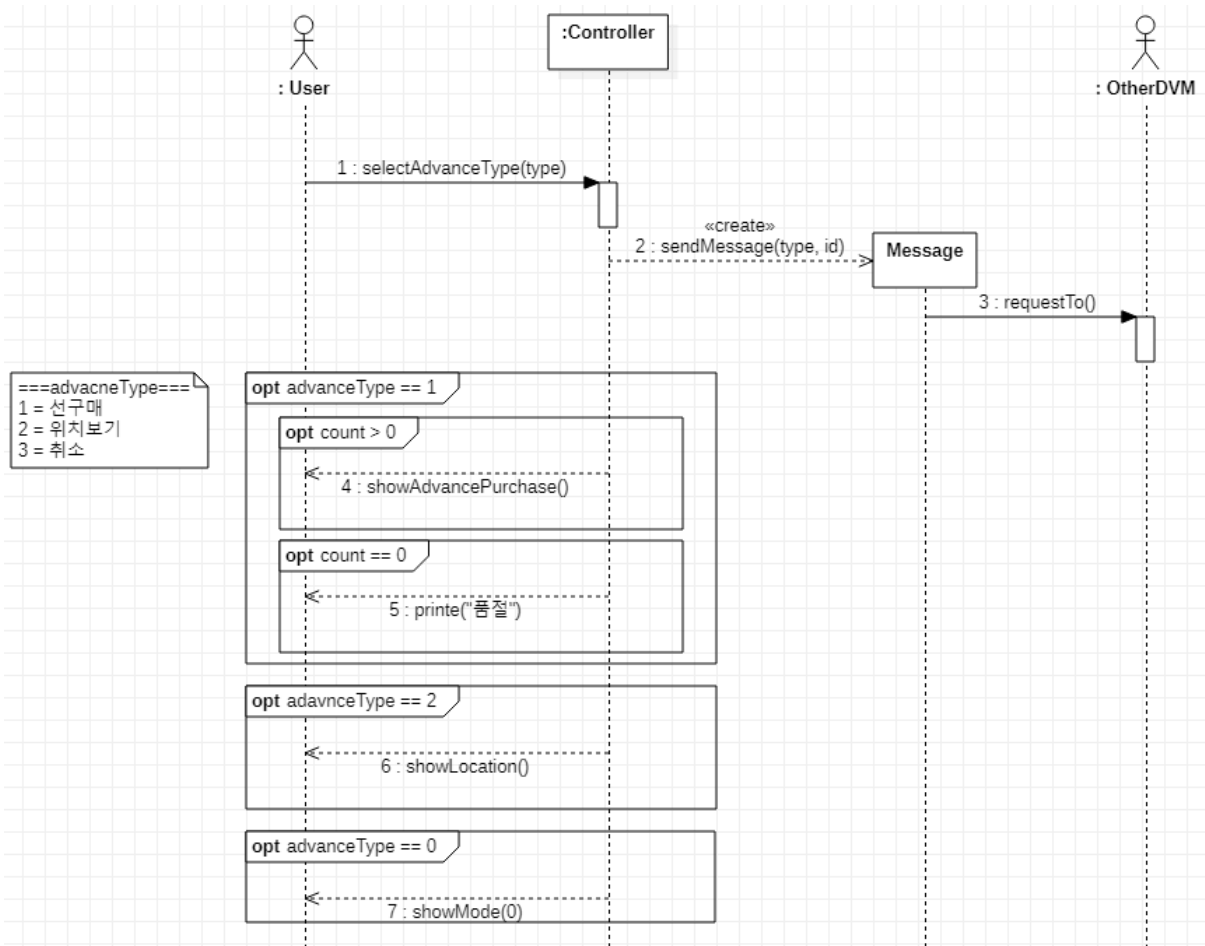

(12) Inform Location

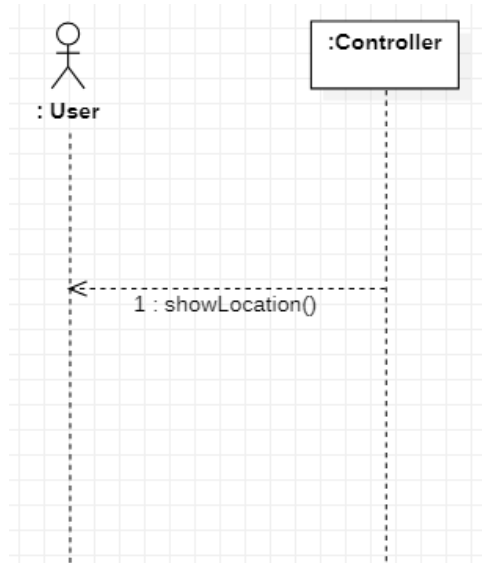

(13) Create Verification Code

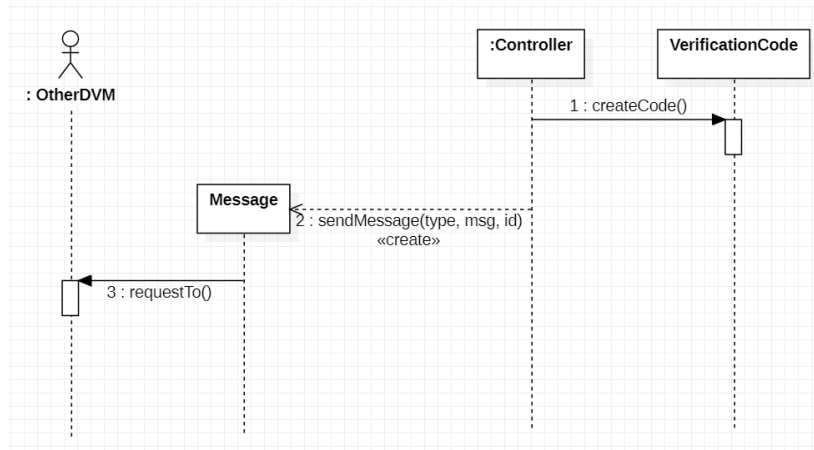

(14) Show Verification Code

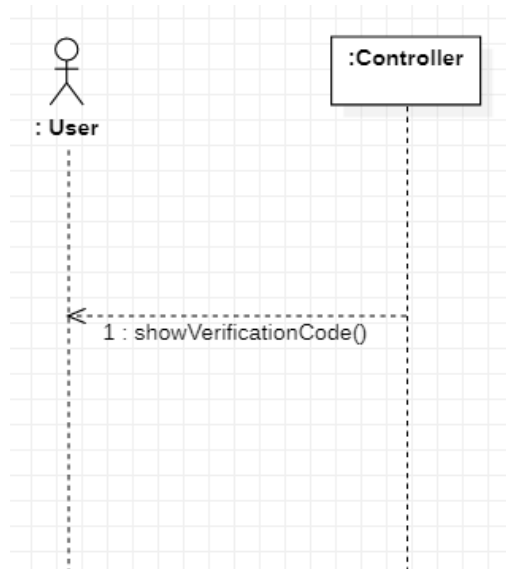

(15) Item Out

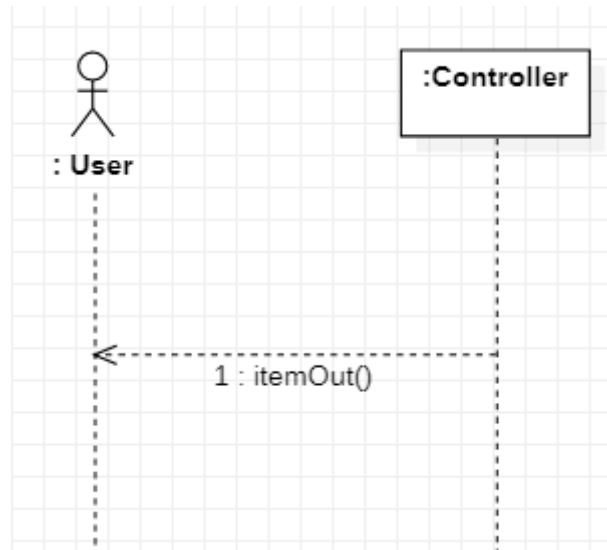

(16) Read Verification Code

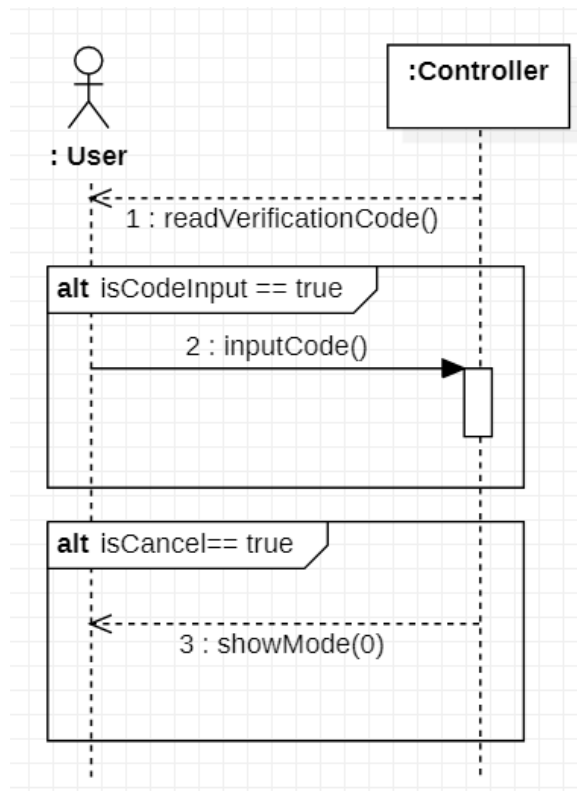

(17) Check Verification Code

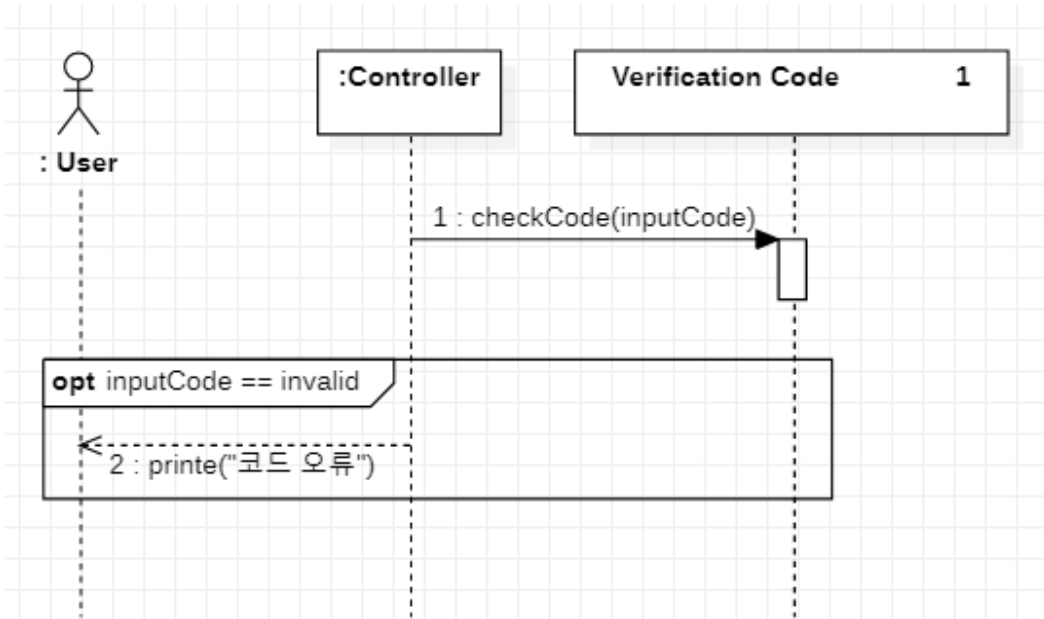

(18) Reset Verification Code

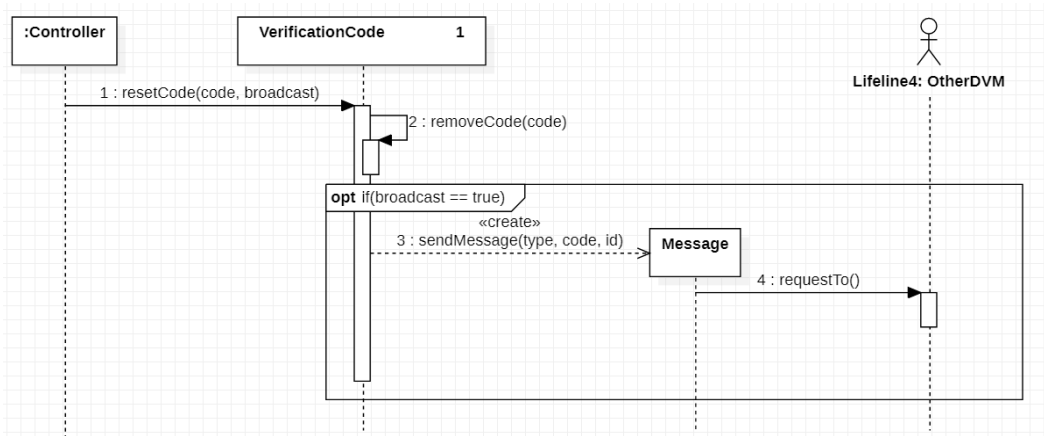

(19) Message Request

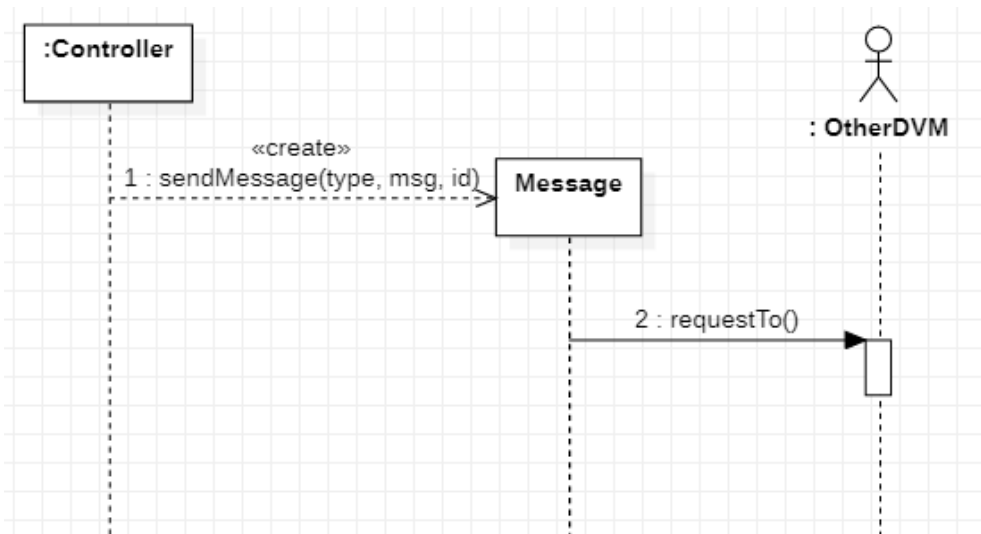

(20) Message Response

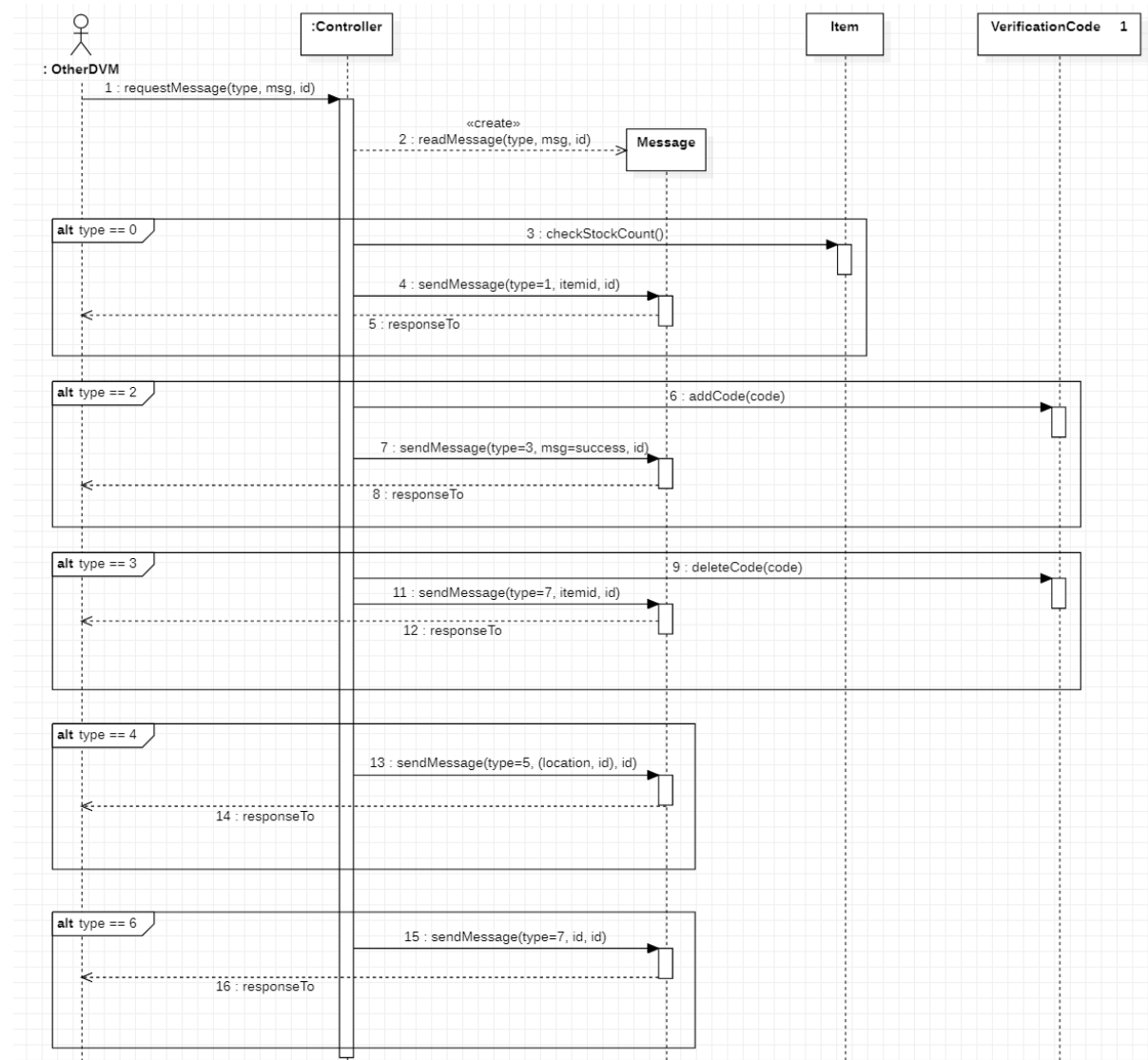

2144. Define Design Class Diagrams

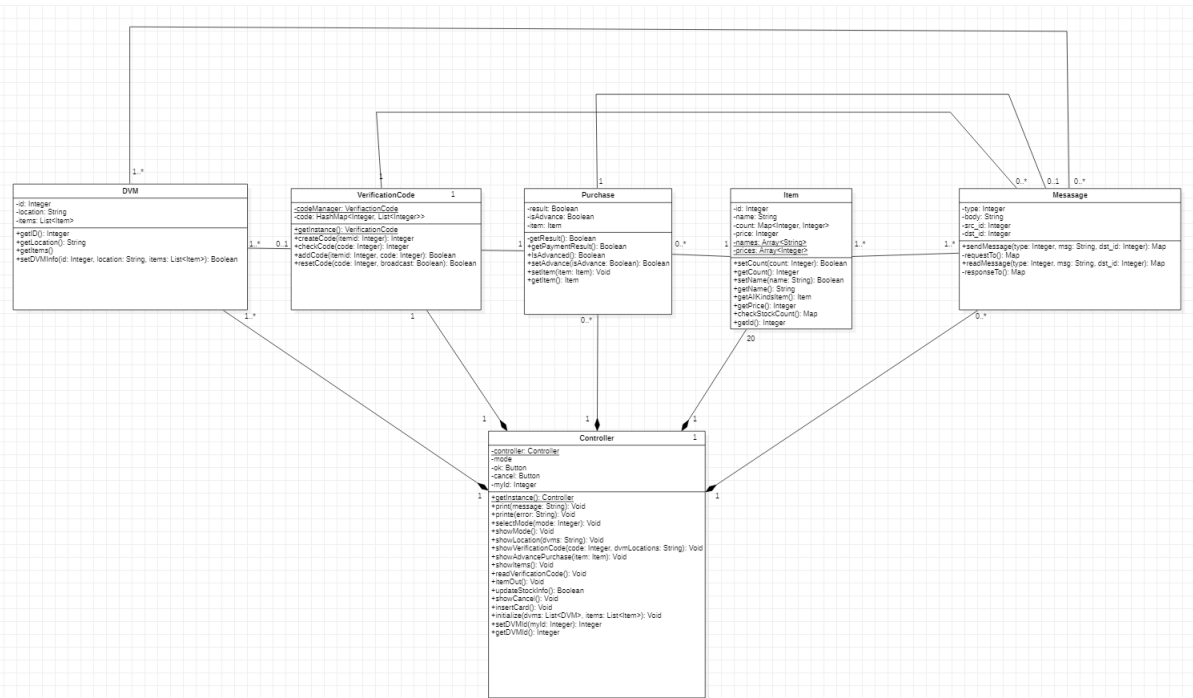

2145. Refine System Architecture

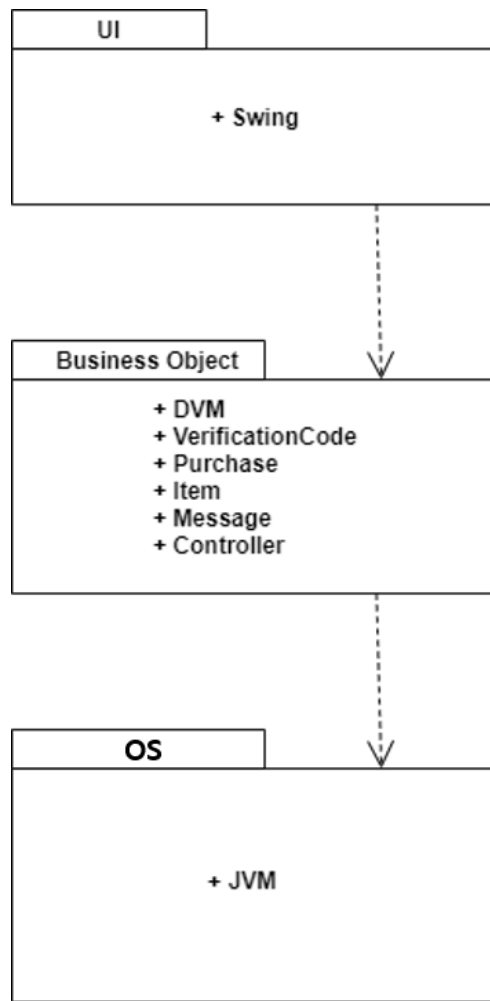

2147. Perform 2040 Traceability Analysis

